

# GASENGINES "1S" CLASSIC

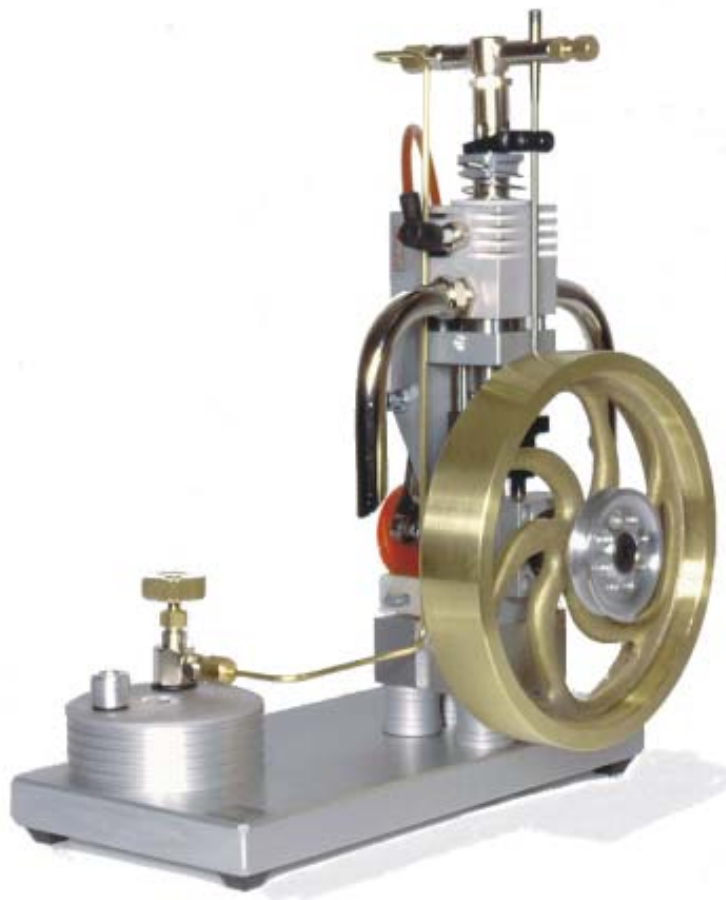

ASSEMBLY PLAN

## ASSEMBLY PLAN

Component parts are to some extent fitted together as subassemblies.

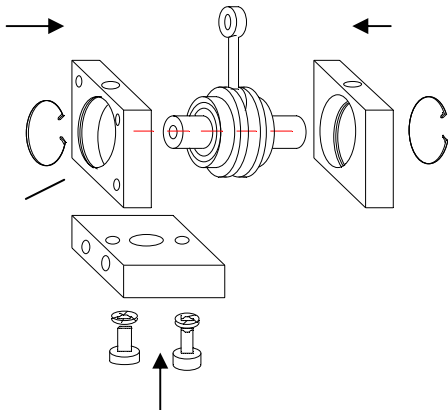

### 1. Mounting the crankshaft bearing

- 1.1 Fit the short crankshaft with both bearings in the bearing plate (4).  
(In case of resistance, you have to support the crankshaft in the middle)
- 1.2 Allow the lock washers (4.1) to snap into the grooves on the outside of the bearing plates.  
(s. sketch)
- 1.3 Loosely screw the base plate (5) with two M3 screws and retaining rings.

### 2. Mounting the crosshead guide

- 2.1 Firmly fasten the right guide rod (6) with M4 threads on the bearing plate.
- 2.2 Fit the crosshead (9) into the guide rod (6), ensure that the M3 connection is on the right.  
(s. sketch)
- 2.3 Fit the connecting rod (7) with cylinder pin (9.1) and piston rod (8) in the crosshead.
- 2.4 Push the second guide rod (6) through the crosshead and fasten it on the bearing plate
- 2.5 Fasten the cylinder plate (3) with M3 screws and retaining rings onto the guide rods; the piston must fit through the centre hole.  
When fastening, the crosshead the top position should be next to the cylinder plate.
- 2.6 Push the crosshead downwards to the bearing plates and then loosen the M3 screw once again and then retighten.  
The crosshead must easily move to-and-fro, (thermal expansion).  
Finally tighten all screws.

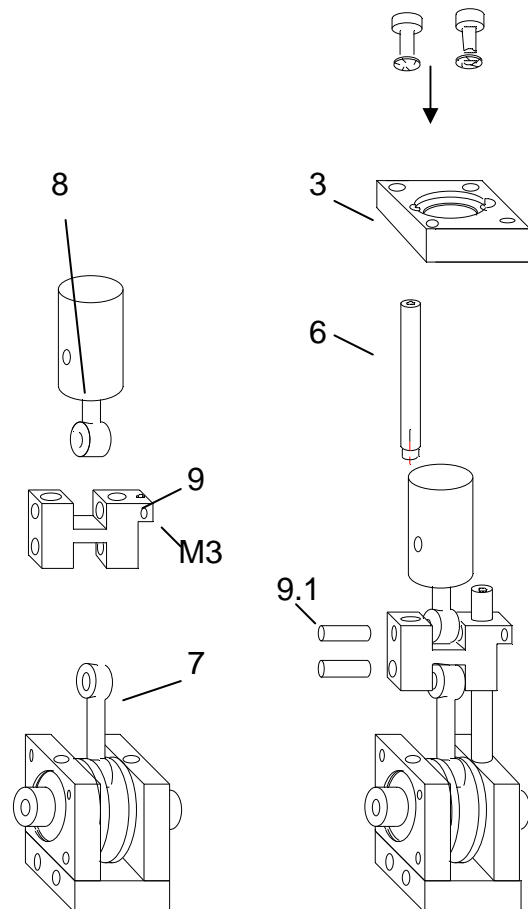

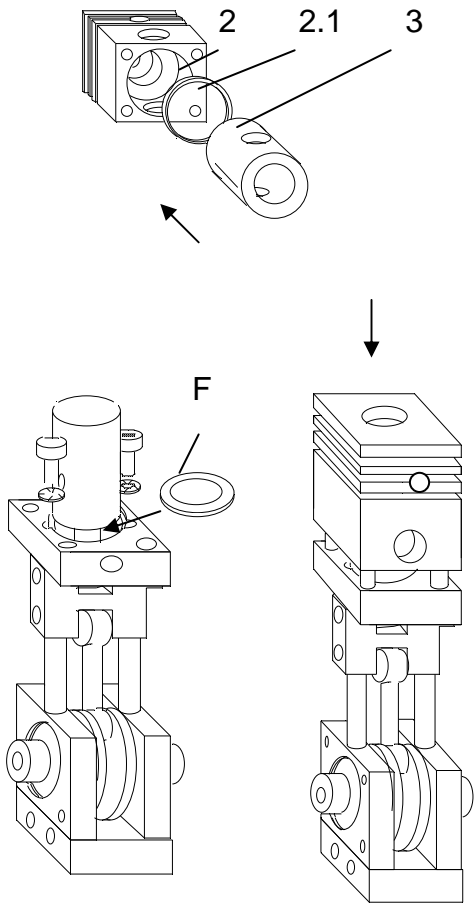

### 3. Mounting the cylinder unit

- 3.1 Insert the Teflon seal (2.1) into the cylinder housing (2) (can be already fitted inside the housing)
- 3.2 Fit the cylinder (3) into the cylinder housing, ascertain that exhaust openings correspond. (sparkplug hole backwards)
- 3.3 The cylinder unit is now to be mounted on the cylinder plate. (Screws M4x20.) First insert a felt-ring seal (F) into the cylinder plate, for lubrication.
- 3.4 Insert the piston into the cylinder and tighten the screw crosswise.
- 3.5 Once again check the engine unit for smooth running and if necessary eliminate strain.

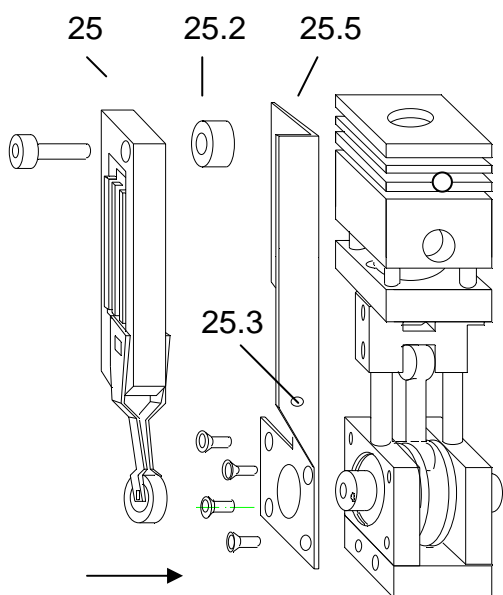

### 4. Mounting the ignition holder

- 4.1 Fasten the ignition device holder mounting bracket 25.5 with 4 countersunk head screws on the bearing plate.
- 4.2 Fasten the ignition device 25 with spacer washer 25.2 and M3 screw onto the holder mounting bracket. Fix the M4 x10 set screw (25.3) with lock nut in the mounting bracket.

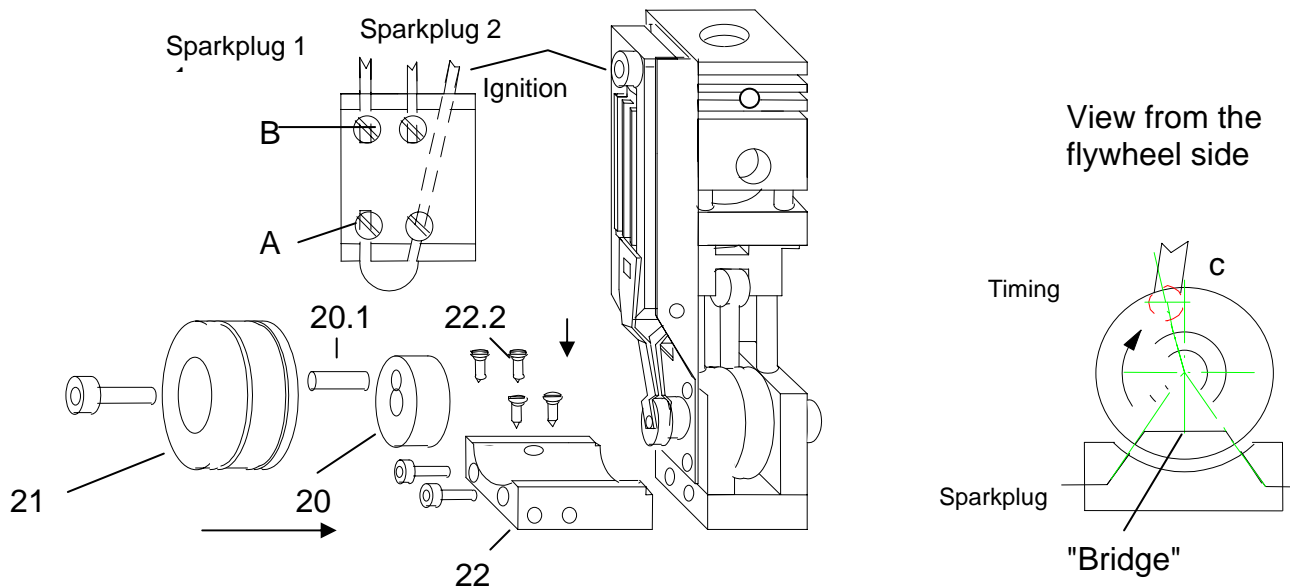

## 5. Mounting the ignition unit.

- 5.1 Mount the stator (22) on base plate (M3 x10).
- 5.2 Push the cable from ignition through the inclined hole on the stator and guide it into the second hole (A).
- 5.3 Push two cables, (red) for the spark plugs, into the short holes on the stator (B).
- 5.4 Drive in the four screws (22.2) completely through the predrilled holes, the screws thereby penetrate the cables insulation and establish the electrical contact.
- 5.5 Stick the pin (20.1) (1.5x 13) into the hole in the crankshaft.
- 5.6 Push the eccentric cam (20) over the pin.
- 5.7 Fasten the rotor (21) with screw (M4 x 30) through the eccentric cam (20) on the crankshaft.

The rotor is to be positioned and fastened such that the "bridge" inside the rotor lies downwards above the screws (22.2) - when the crankshaft has nearly reached the top dead centre (approx. 3 degrees earlier), (c) - so that high-voltage sparking occurs.

- 5.8 Fasten the sparkplug (23/24) tightly on the cylinder housing and then fix the red cable with cap.
- 5.9 Unscrew the exhaust (47).
- 5.10 Drive in the screw M4 (25.3) into the bracket so deeply onto the ignition that when rotating the crankshaft the high-voltage sparks over on the rotor.

The sparkplug should be checked through the carburettor opening because the sparkplug is no longer tight if the plastic part is repeatedly unscrewed.

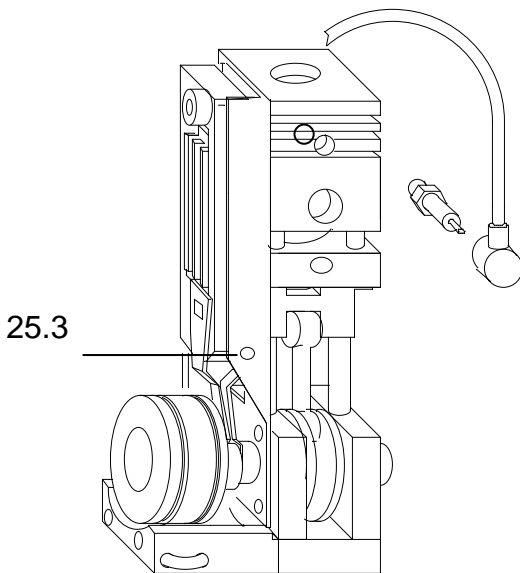

6.2 Fasten the flywheel (14) on the crankshaft end with M6 thread connection (for CL with the belt pulley)

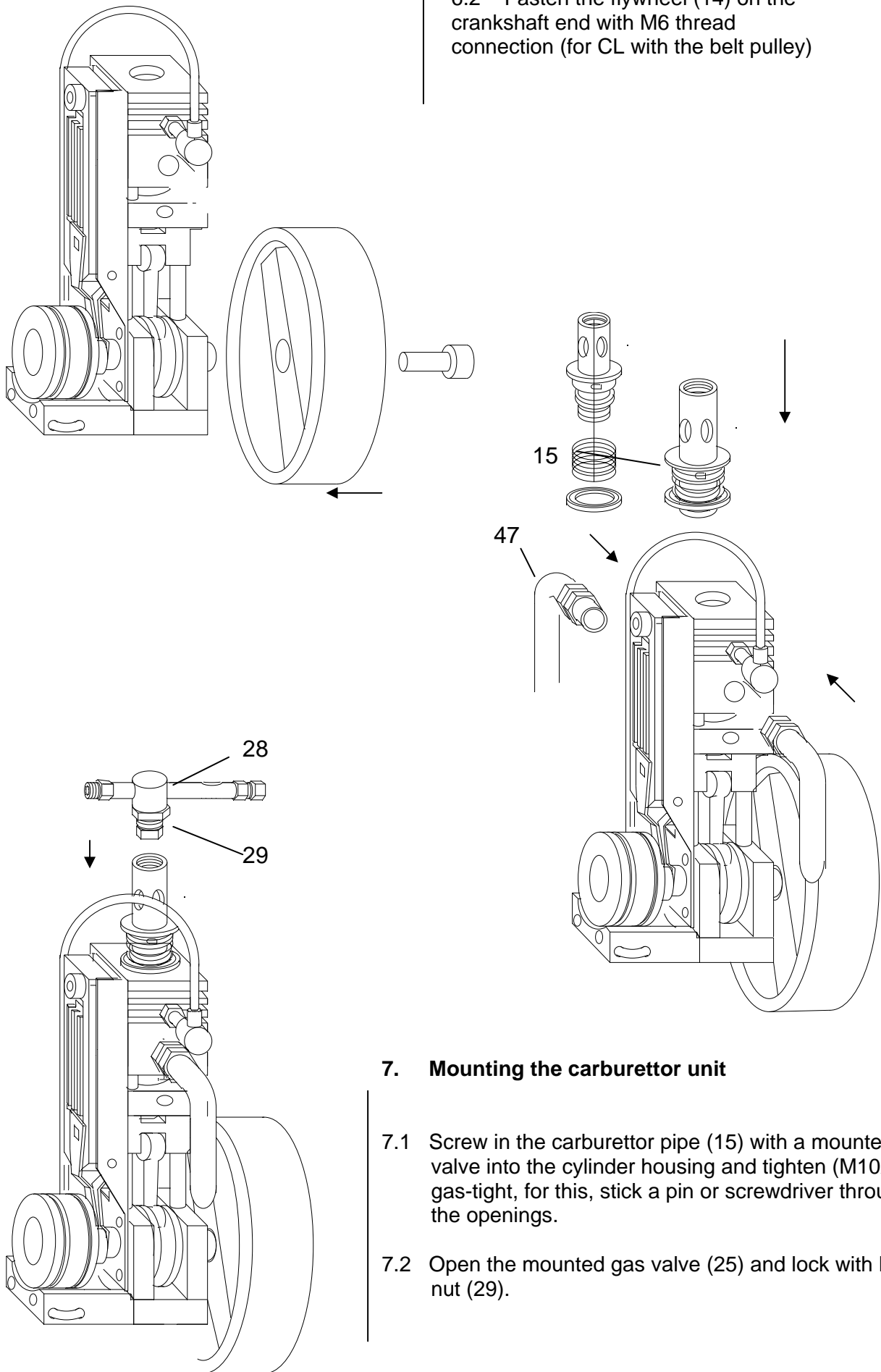

## 7. Mounting the carburettor unit

- 7.1 Screw in the carburettor pipe (15) with a mounted valve into the cylinder housing and tighten (M10x1) gas-tight, for this, stick a pin or screwdriver through the openings.
- 7.2 Open the mounted gas valve (25) and lock with lock nut (29).

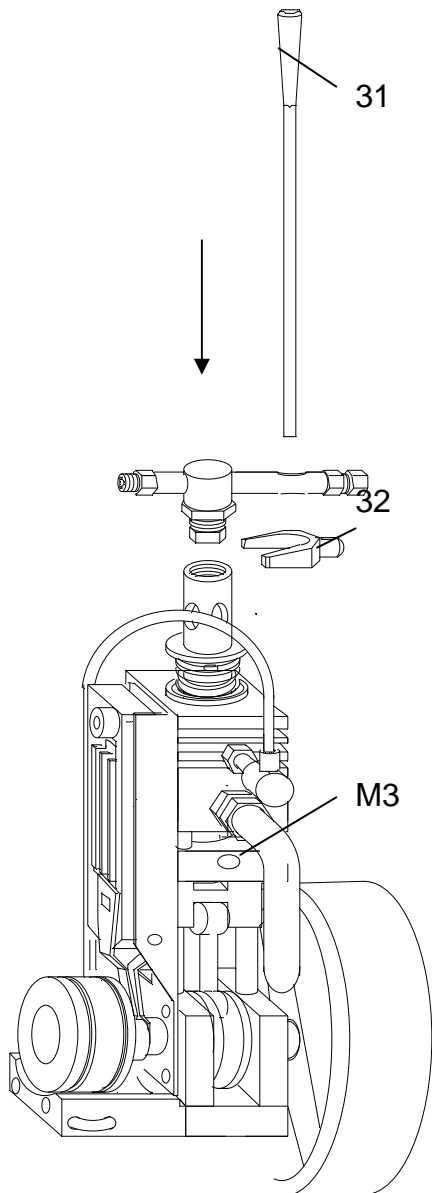

## 8 Mounting the valve control

Screw in the stud bolt M3 into the threaded hole in the crosshead.

8.2 Guide the control lever with tapered end (31) through the hole on gas valve.

8.3 Push the catch (32) over the control lever.

8.4 Fasten the control lever in the crosshead with M3 screws.

8.5 Fasten the catch on the control lever (M3) such that when the crankshaft is at the bottom dead centre, the valve spring 2/3 is compressed.

(From the top of control lever approx. 38 mm.)

8.6 Mount the exhaust pipes (47)

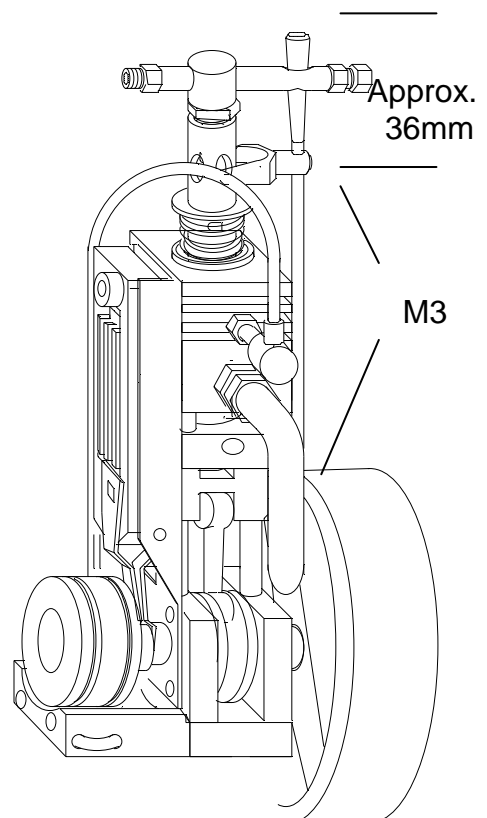

## 9. Mounting the gas distributor

- 9.1 Fasten the distributor (49) with M4 screws and screw the seal on the prism

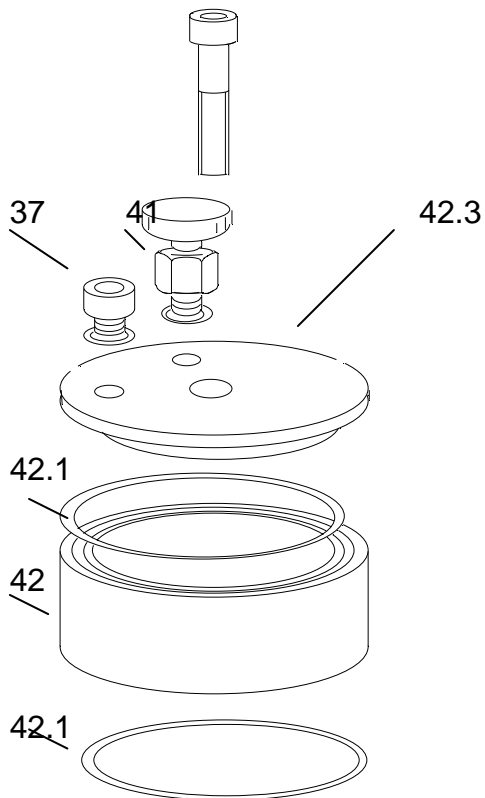
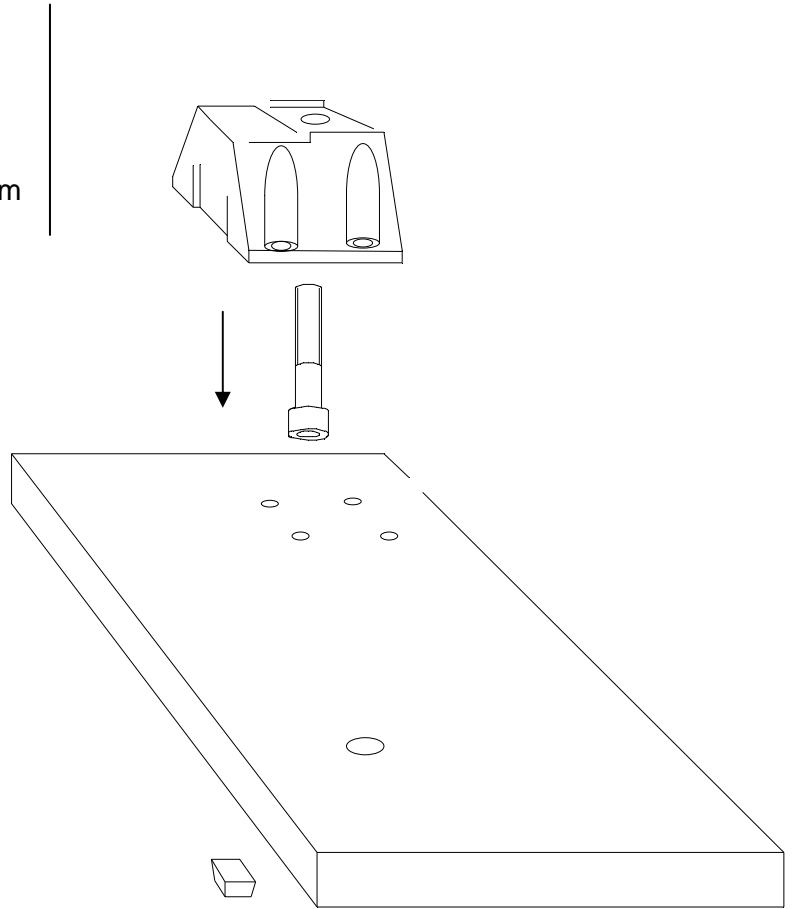

## 10. Mounting the tank

- 10.1 Insert the seals into the grooves of tank ring (42).
- 10.2 Screw the gas tank cap (42.3) and ring with M6 screws and seal washers (42.1) on the base plate
- 10.3 Screw in the gas tank valve (37) and gas control valve (41) with the seals inside gas tank cap, taking care of the position of gas connection. (For adjustment, the tank cap can also be screwed.)
- 10.4 Tighten the tank cap
- 10.5 Check the tank for air-tightness.

11. Mounting the engine on base plate

12. Mounting the gas pipes

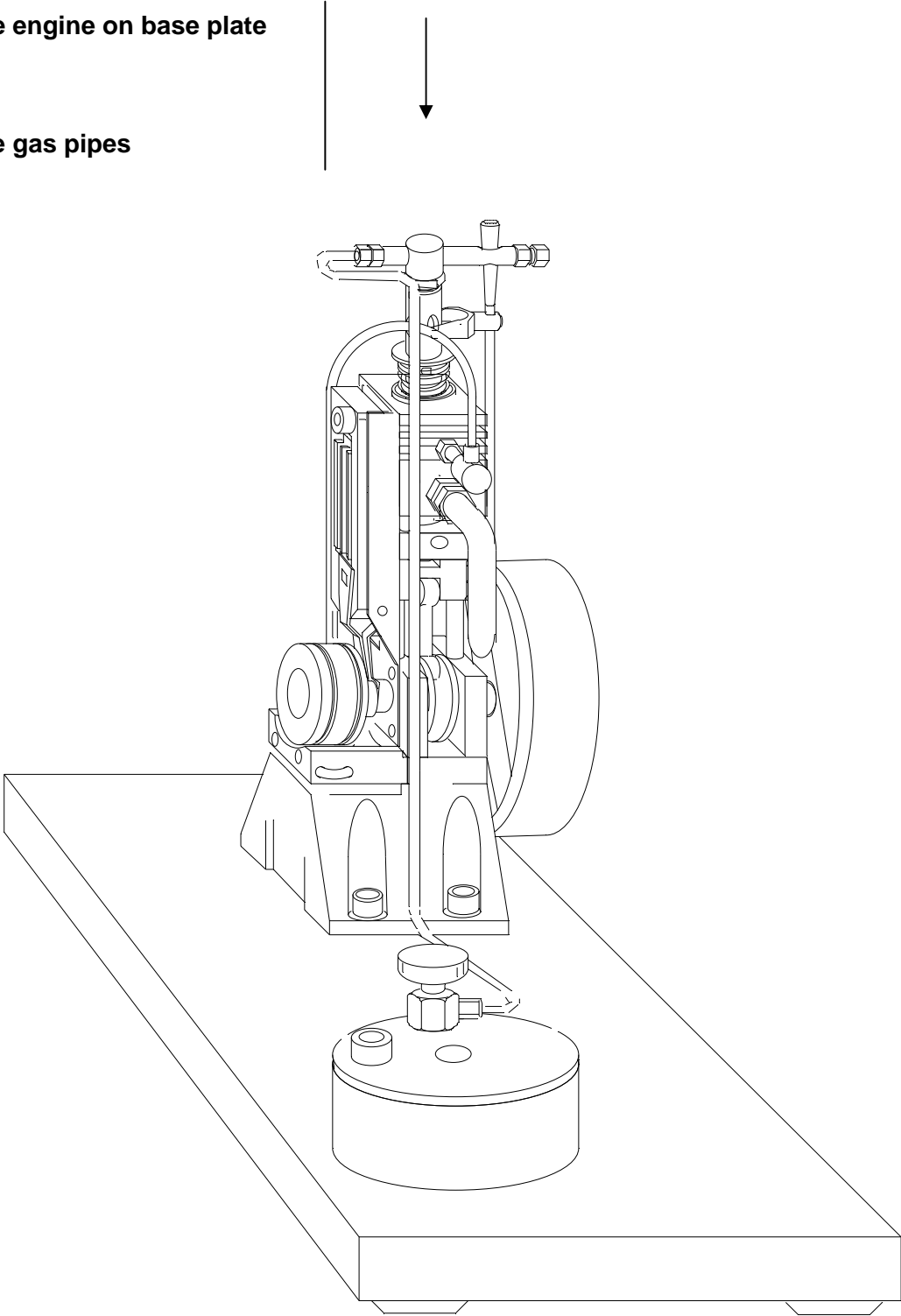



### 13. Putting into operation and tuning

- 13.1 Check ignition once again  
Ignition spark must flash approx. 3 degrees prior to the top dead centre of both crankshafts
- 13.2 Open the gas valve on gas tank and check lines for gas-tightness.
- 13.3 On both gas valves screw in the setting screw (34) into the valve 28, far enough until gas flows out of the nozzle at the bottom dead centre of the crankshaft.
- 13.4 Start the engine by rapidly rotating the flywheel clockwise, for instance, with the thumb and index finger on the spoke or depending upon model, on the circumference with the palm.
- 13.6 The desired rotational speed of the engine can now be regulated with gas valve on the tank.

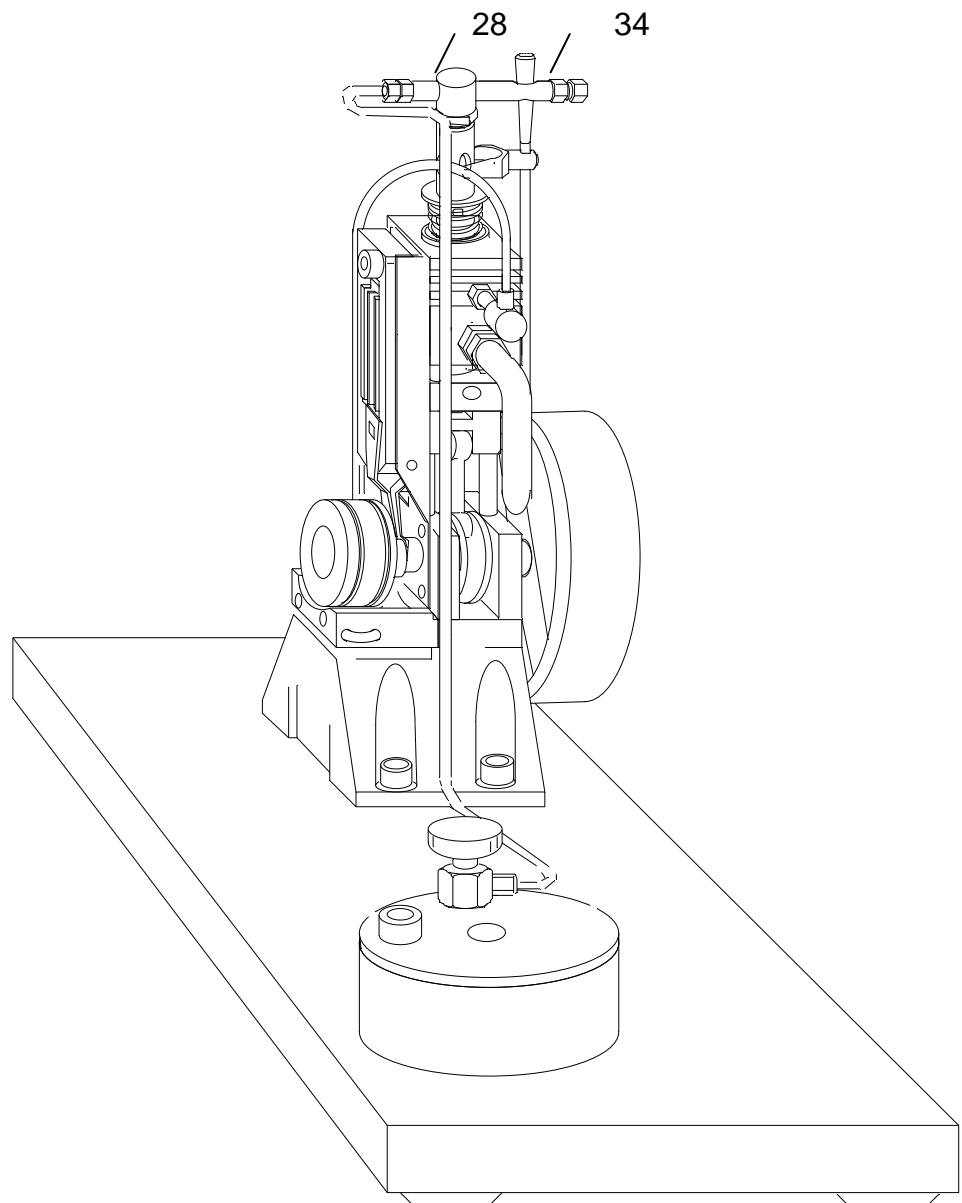

### Maintenance

Guide rods and the connecting rod bearing should be lubricated after a long period of operation. Use oil without resin content to lubricate the piston through the hole inside the cylinder plate.